

# Cord Zero User and Installer Manual

cord



[www.cord-ev.com](http://www.cord-ev.com)

# Safety and Warnings

Save these instructions. Read all instructions before installing or using the charger.

1. Keep the charger away from explosive or flammable materials, chemicals, vapours, and other hazardous objects.
2. Keep the charger socket clean and dry. If it gets dirty, wipe it with a clean, dry cloth.
3. Do not touch the socket pin when the unit is powered on.
4. Only a qualified technician is allowed to install this charger. The installation must comply with local, regional and national regulations.
5. Do not use the charger if it is showing any visible product damage such as cracks, abrasions, exposed cables, and other visible defects or is showing an error state. In the event of such damage, contact a qualified technician immediately.
6. Do not attempt to disassemble, repair, or refit the charger. If necessary, contact a qualified technician. Improper operation will result in device damage, electric leakage, and other hazards.
7. If any abnormal condition occurs, turn off incoming power supply immediately.
8. Where possible, please ensure the charger is protected against lightning and heavy rain.
9. Keep children away from the charger.
10. Only use the charger for charging your electric vehicle while it is parked and stationary.
11. Our packaging materials are environmentally friendly and can be recycled. Please recycle packaging in appropriate containers. Do not dispose of this device with household waste. It should be taken to a suitable facility for recycling electrical and electronic devices. For more detailed information about recycling this device, please contact your local city/town council office or your household waste disposal service.



## Warning!

The device can be in an electrically energised state. There is a risk of shock and electrical hazards. Please strictly observe all warnings on the device and user manuals. The cover of the charger is only to be removed by a qualified electrician.

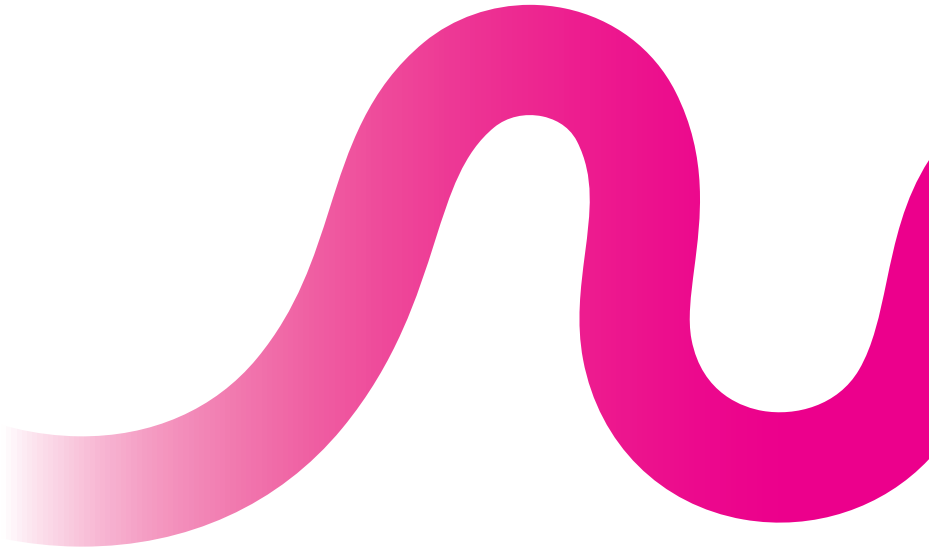

# Contents

Safety and Warnings.....	1
--------------------------	---

1. Introduction.....	5
----------------------	---

## Installation Guide

2. Product Introduction.....	7
------------------------------	---

2.1 Charger internal view.....	7
--------------------------------	---

2.2 Charger visual overview.....	8
----------------------------------	---

3. Package Contents.....	9
--------------------------	---

4. Operation Instructions.....	10
--------------------------------	----

4.1 Installation preparation.....	10
-----------------------------------	----

4.1.1 Tools required.....	10
---------------------------	----

4.1.2 Cables and materials.....	10
---------------------------------	----

4.2 Installation process.....	10
-------------------------------	----

4.2.1 Installation notice.....	10
--------------------------------	----

4.2.2 Pre-installation checks.....	11
------------------------------------	----

5. Installation Details.....	12
------------------------------	----

5.1 Mounting.....	12
-------------------	----

5.2 Electrical wiring.....	13
----------------------------	----

5.2.1 Wiring and CT clamp connection.....	13
---	----

a. Power cable.....	13
---------------------	----

b. 4G sim installation.....	14
-----------------------------	----

c. CT clamp connection.....	14
-----------------------------	----

6. Power on Safety Checks.....	16
--------------------------------	----

7. Installation Tests (Recommended).....	17
--	----

7.1 Charger Access Point (AP) page configuration.....	17
---	----

7.2 RCD test setup.....	20
-------------------------	----

<b>8. Charger Commissioning on Evcharge App</b>	<b>23</b>
a. Evcharge QR code commissioning	23
b. Manual integration	24
c. Check for nearby chargers	26
<b>9. Network Settings</b>	<b>28</b>
<b>10. Load Balance</b>	<b>28</b>
<b>11. Final Setp</b>	<b>29</b>
<b>End User Guide</b>	
<b>12. Cord EV Charging App User Guide</b>	<b>31</b>
<b>13. Charging Operation LED Indication</b>	<b>32</b>
13.1 Charging using app	32
13.2 Charging using Plug & Play	33
13.3 Charging using RFID card	35
<b>14. UK EV Smart Charge Point Regulation</b>	<b>36</b>
14.1 Randomised delay	37
14.2 Loss of communications network access	37
14.3 Default charge schedule	38
14.4 Cyber security	40
<b>15. Troubleshooting</b>	<b>40</b>
15.1 Indicator status	40
15.2 Fault code and resolution	41
15.3 Forgot the Access Point password?	42
<b>16. Maintenance</b>	<b>42</b>
<b>17. Security Events and Customer Support</b>	<b>43</b>
17.1 Security events	43
17.2 Cord customer support	43

# 1 Introduction

Item	Parameters	Description
<b>Input</b>	Power Supply	Single Phase (1P+N+PE)
	Rated Voltage	230V AC
	Rated Current	32A
	Frequency	50Hz
<b>Output</b>	Output Voltage	230V AC
	Maximum Current	32A
	Rated Power	7kW
<b>User Interface</b>	Charge Connector	Type 2 cable
	Cable Length	5m or 8m
	Enclosure	Plastic PC943
	LED Indicator	Green/Yellow/Red
	RFID Reader	Mifare ISO/IEC 14443 A
	Start Mode	Plug &Play / RFID card / Monta app
<b>Communication</b>	Communication	Wi-Fi 2.4GHz or 4G
	Protocol	OCP 1.6J
<b>Safety</b>	Built-in RCD protection	RDC-PD with type A + DC 6mA according to IEC 62955
	Ingress Protection	IP65
	Impact Protection	IK08
	Electrical Protection	Over current protection, Residual current protection, Ground protection, Surge protection, Over/Under voltage protection, Over/Under frequency protection, Over temperature protection, PEN Fault Protection
	Certification	BS EN IEC 61851-1:2019, IEC62955, BS IEC 61851-21-2:2021, BS EN IEC 61000-6-1:2019, BS EN IEC 61000-6-3:2007+A1, BS7671:2018-amd2:2022 722.411.4.1(iv), EN 300 328 V2.2.2:2019, EN 300 330 V2.1.1:2017, EN 301 489-1 V2.2.3:2019, EN 301 489-3 V2.1.1:2019, EN 301 489-17 V3.2.0:2017, EN 62311:2020, BS7671:2018-amd2:2020 722.411.4.1(iv)
	Class of equipment	Class I
	EMC level	Class B
	Pollution degree (PD)	PD 3
	Earth type	TN
	Warranty	3 years
<b>Environment</b>	Installation	Wall-mount/Floor-stand Installation
	Usage environment	Indoor & outdoor
	Work Temperature	-30°~+50°
	Work Humidity	5%~95%
	Work Altitude	<2000m
<b>Package</b>	Product Dimension	344 x 192 x 100 mm (H x W x D)
	Package Dimension	430 x 330 x 235 mm (L x W x H)
	Net Weight	3.1kg
	Gross Weight	3.6kg

# Installation Guide



## 2 Product Introduction

### 2.1 Charger internal view



## 2.2 Charger visual overview

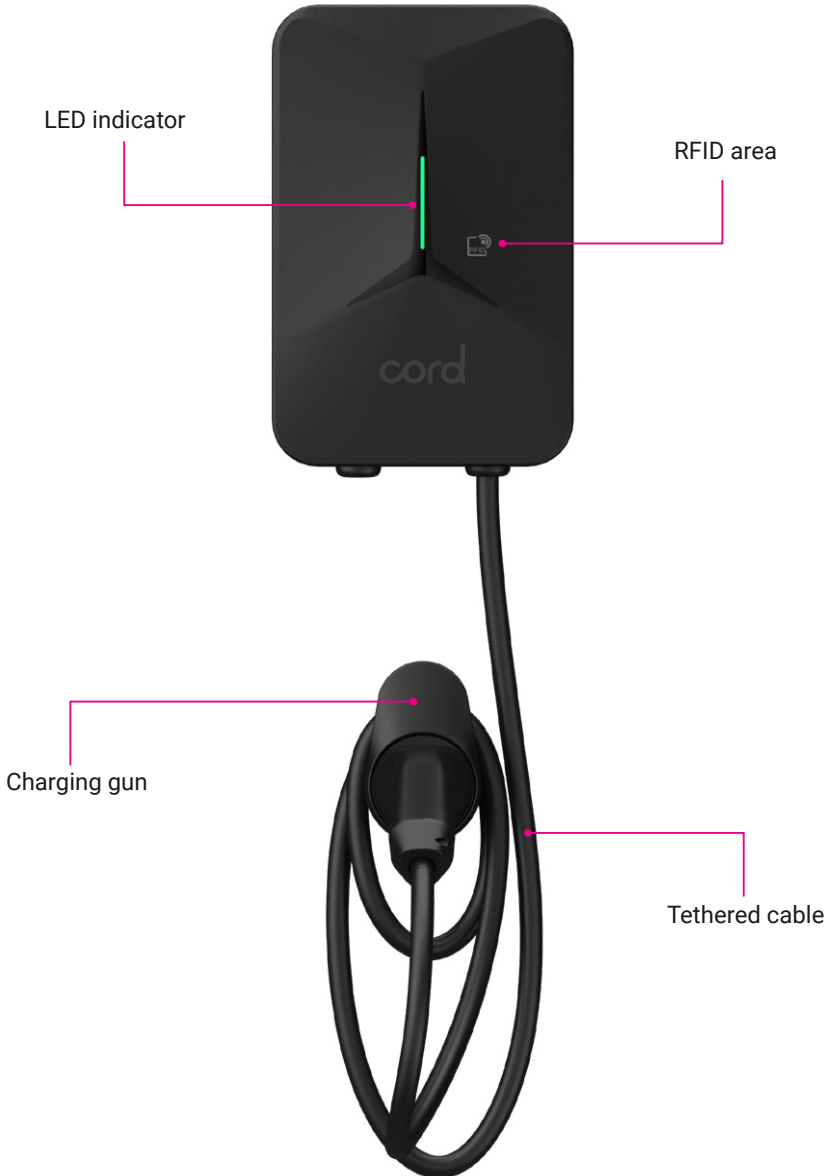

# 3 Package Contents













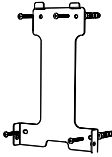

Once opened, please carry out the following inspections:

## Visual inspection

Visually inspect the charger's external appearance. If there is any breakage or damage, please notify the supplier immediately.

## Item inspection





Confirm that all the items listed below are included with your product. If there is a shortage in the quantity of any item, or if any items are missing, please contact the supplier immediately.

				
EV charger (x1)	User manual (x1)	6 Wall plugs (x8)	M4*32 screw (x8)	Mounting plate (x1)
				
H2.4 hex key (x1)	Wire ferrules (x3)	Cable holder (x1)	RFID card (x2)	Bracket (x1)
				
M4x12 screw (x2)	CT clamp (x1)	Compact wire connector (x1)	Extension cable (x1)	Extra CT clamp plug (x1)

# 4 Operation Instructions

## 4.1 Installation preparation

### 4.1.1 Tools required

Tool Name	Photo	Function
Multimeter		Test electrical connection and electrical parameter
Cross head screwdriver		Tightening screw
Electric drill		Drilling of mounting holes
Diagonal pliers		Cable cutting

### 4.1.2 Cables & materials

Name	Specification	Quantity
Power supply cable	Single-phase power supply cable Maximum Cross-Sectional Area: 6mm <sup>2</sup>	As required
RCBO	Type A or Type F Double Pole	1

The use of extension cords, adapters, and converter adapters is strictly prohibited.

**Note:** Only a Type 2 male connector can be connected to the EV charger socket.

## 4.2 Installation process

### 4.2.1 Installation notice

- Electrical devices should only be installed and maintained by qualified technicians. No responsibility is assumed by the manufacturer for issues arising as a consequence of installation by an unqualified person. A qualified technician is an electrician who has certified skills and knowledge related to the construction, installation, and operation of this type of electrical device and who has received safety training to recognize and avoid the hazards involved.
- All applicable local, regional, and national regulations must be applied when installing, repairing, and maintaining this device.
- The charger is equipped with 6mA DC Current Leakage Protection function which conducts an automated test for the 6mA DC.

- An approved Type A RCBO with earth leakage protection of 30mA and 40A current rating must be installed separately in the consumer unit by the installer.
- The charger is equipped with PEN Fault Protection and an automatic disconnection system which satisfies the requirements of BS7671:2018 Amendment 2:2022 722.411.4.1 (iv) the 18th Edition IET Wiring Regulations.
- In the event of the utilization voltage at the charger between live and neutral conductors being greater than 253 V rms or less than 207 V rms within 5s., this device provides protection from electric shock by electrically disconnecting the vehicle from the live conductors of the supply and from protective earth.
- The point above implies the charger can be installed without the need for an additional earth rod. However, if the customer or local regulations require that an earth rod is installed (for instance as part of an earthed system), then this should be connected to the dedicated terminal within the charger.

#### **4.2.2 Pre-installation checks**

- Ensure that the site of installation meets the charger's technical specification and that there is no uncontrolled hazard arising from installation of this unit.
- Ensure the charger's location allows good operational access for normal use, repair, and maintenance.
- The AC input components for the power supply on site are to be correctly fitted with required protection devices prior to installation of the charger as per local, regional, and national regulations.
- Ensure that the charger location has good network connectivity:
  - This charger only supports 2.4GHz network. Wi-Fi signal strength between -50dBm to -60dBm is considered good.
  - A 2.4GHz Wi-Fi extender may be needed if the signal strength is below the range of -60dBm to -80dBm.
  - The Wi-Fi signal strength can be checked by utilising a Wi-Fi speed test app using a mobile phone.

# 5 Installation Details

## 5.1 Mounting

1. Using the enclosed Mounting plate, mark the locations of the holes.
2. Drill holes at the marked spots and insert the wall plugs
3. Insert the screws into the bracket's mounting holes and tighten them into the wall plugs, leaving a 5mm gap between the screw head and the wall.

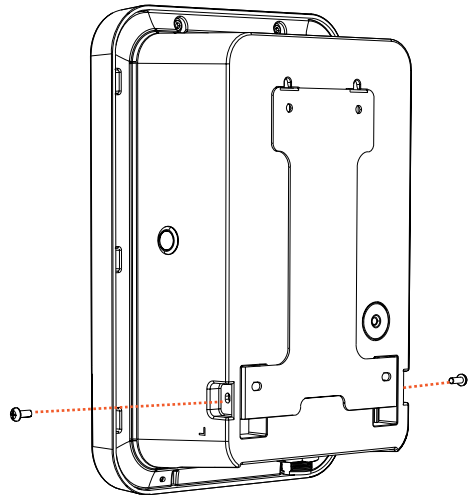
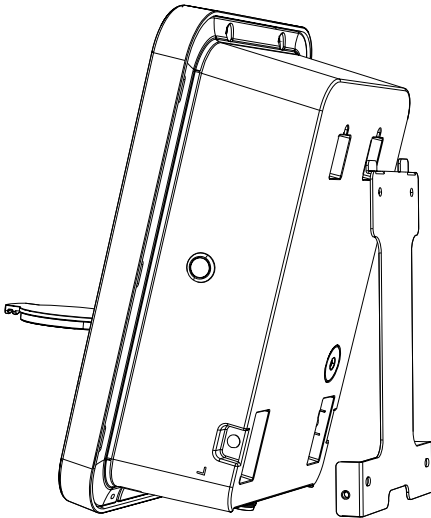
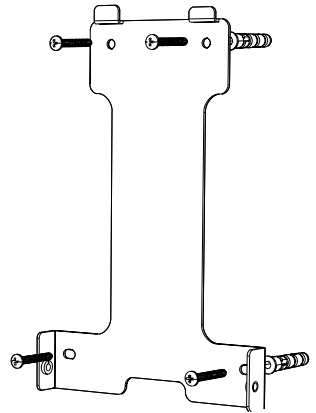

4. Hang the EV charger onto the bracket's two mounting screws, ensuring a secure fit.
5. Tighten the screws on both sides to secure the EV charger.

## 5.2 Electrical wiring



### NOTE:

- ENSURE TERMINAL BLOCKS ARE IN THE OPEN POSITION BEFORE WIRING THE CHARGER.
- THE RECOMMENDED SCREW TORQUE IS 2 NM. IT IS ADVISED TO USE AN ELECTRIC SCREWDRIVER WHEN SECURING THE INPUT POWER CABLE.

### 5.2.1 Wiring and CT clamp connection

#### a. Power cable

1. Remove a length of 40mm of the cable jacket and strip the wire insulation to a length of 8~15mm.
2. Crimp the terminals with wire ferrules as shown in the figure below.



Single-phase wiring

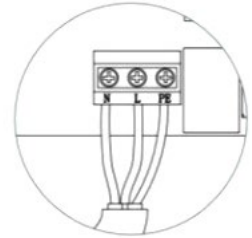

Single-phase connection

3. Distinguish PE, N, L, then insert the wire into the corresponding wire slot. Please ensure that the line and neutral cable are installed properly without overbend. Overbent cables may loosen the connection over time and result in a critical fault.

#### b. 4G sim installation

- If 4G is required, install the SIM in 4G sim port (Note: This may be pre-installed).

#### c. CT clamp connection

- Connect the CT connector to the CT port as shown in Fig 3.
- Connect the CT clamp to the same phase of the consumer unit where the charger is connected. Make sure this step is done only after the CT connector is connected to charger to prevent electrical hazards.
- Ensure that the CT clamp is connected tightly with the correct polarity, both in the charger and distribution unit. Please check the images on the next page.

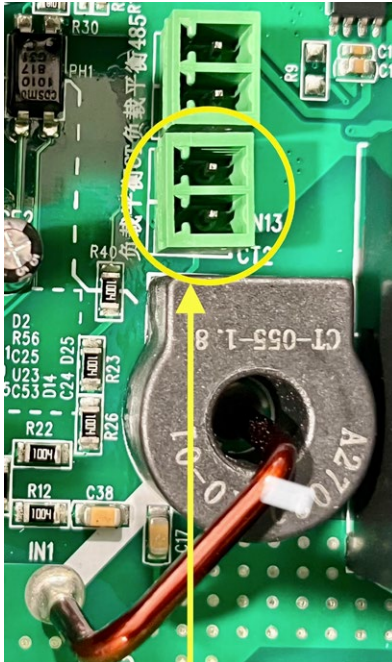

Fig 1. CT port for load balance



Fig 2. CT Clamp



Fig 3. CT Clamp Connection

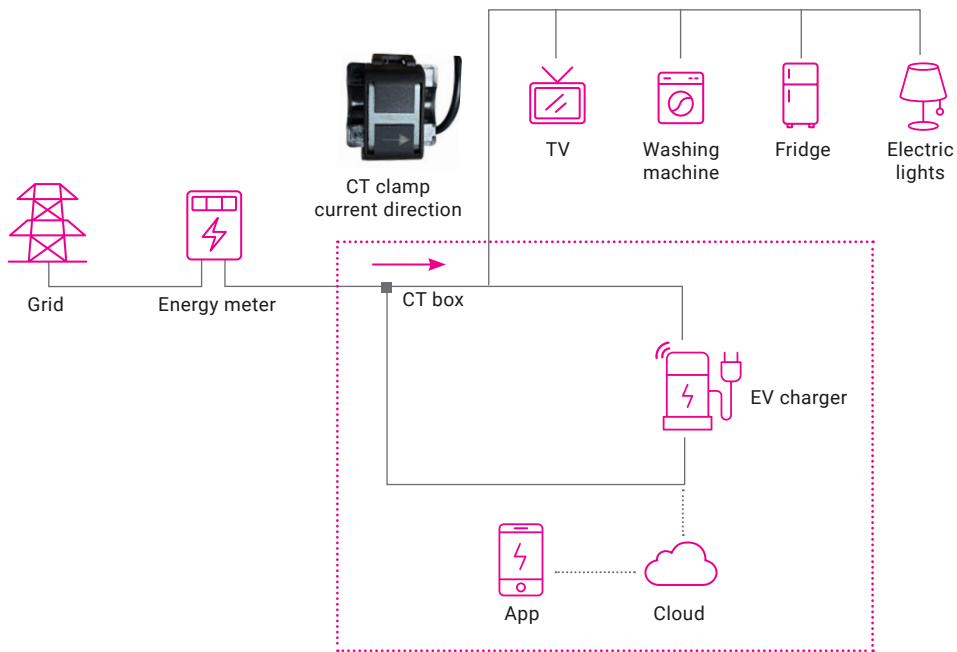

Fig.4 CT clamp connection diagram

# 6 Power-on Safety Checks

## 6.1 Power-on safety checks and network configuration

### 6.1.1 Checks before power-on

Please check / re-check the following items prior to the initial Power-On:

- The charger's location allows for good operational access to its normal use, repair, and maintenance.
- The AC input components within the power supply at the installation location are fitted correctly with the required electrical and mechanical protection components prior to installation of the charger.
- Ensure that there is no visible damage to the electrical cable and the unit.
- Confirm the charger is installed correctly, as per the instructions in this manual.

### 6.1.2 Power-on status

When powering on the charger, the LED indicator should be in standby state.

State	Description	Led Status
<b>Ready to charge/ standby</b>	Standby or charge gun plugged into vehicle, charging not yet started	Pulsing green
<b>Charging in progress</b>	Charge gun plugged into vehicle and charging in progress	Flashing green, 200ms on, 1s off, cycle
<b>Fault has occurred</b>	An error condition has occurred. See Section 14 (Troubleshooting) for details of error conditions	Flashing red or constantly red

# 7 Installation Test (Recommended)

## 7.1 Charger Access Point (AP) page configuration

This configuration applies for a single charger with residential load.

This balances energy use and adjusts the charging output to your electric vehicle in response to changes in electricity load.

### Step 1: Airplane mode

Please switch your smartphone to airplane mode.



### Step 2: Power reboot

- Restart the power of the charger and ensure the LED displays a pulsing green light pattern.
- Please note that network configuration setting is only accessible 15 minutes after the power reboot.



### Step 3: Charger Wi-Fi

- Turn on your smartphone Wi-Fi.
- Select the Wi-Fi hotspot that contains your charger's serial number (beginning with SN100...).

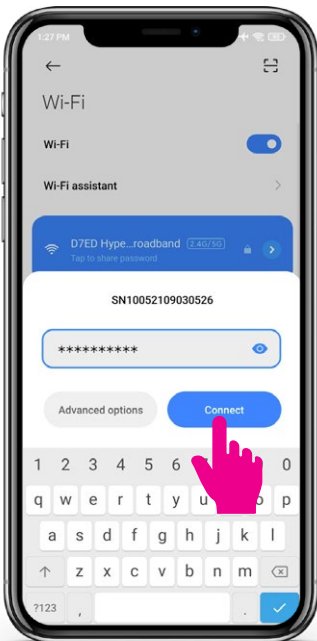
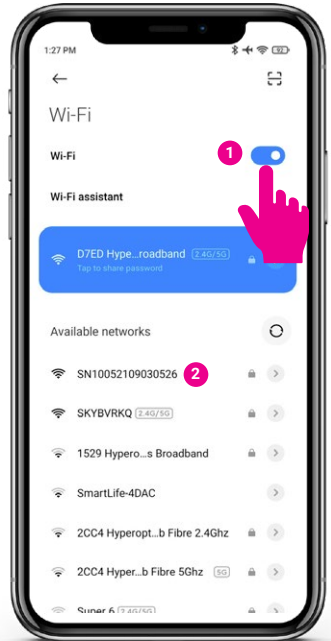

### Step 4: Input charger Wi-Fi password

- Input the Wi-Fi password found on the sticker located on the side of the charger.
- Select 'Connect'.

### Step 5: Automatic network switch

Select “No Thanks” when the pop-up Wi-Fi network message appears. The smartphone can communicate with the charger without internet connection.

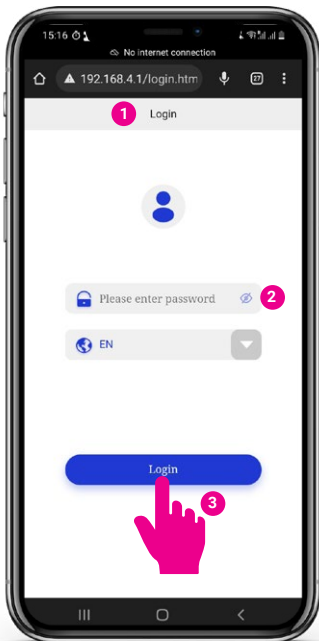
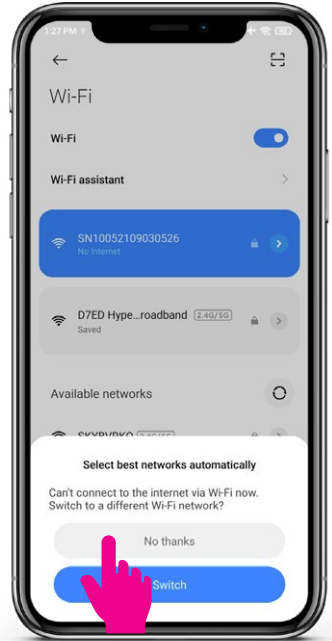

### Step 6: Login credentials

- Enter the numbers 192.168.4.1 into your web browser.
- Input the four digit network pin from the side of the charger.
- Select 'Login'.

## Step 7:

- Input a new 8-digit password, following the requirements, to replace the 4-digit PIN code for accessing the charger settings.
- Select 'Confirm'.
- The charger will redirect to the login page, allowing them to log in using their newly updated password.

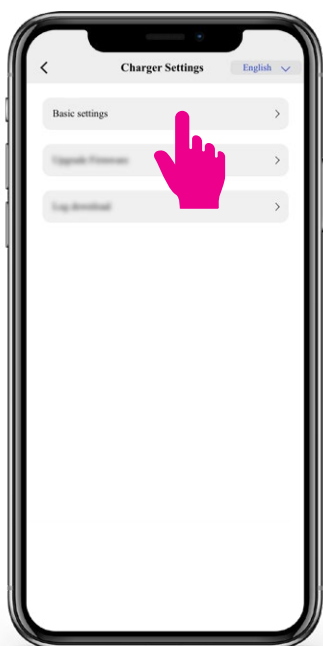
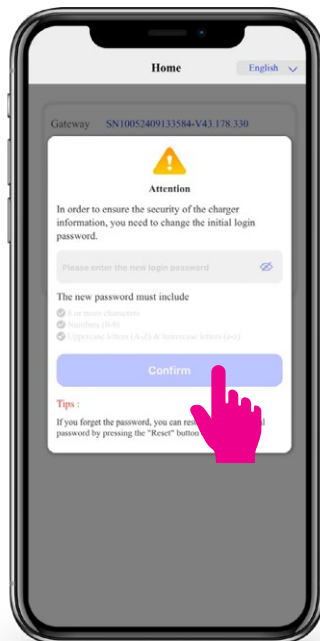

## 7.2 RCD test setup (recommended step)

Testing the RCD can ensure that it is working properly and will provide shock protection in case of an electric fault.

This test should only be carried out by a qualified technician.

### Step 1: Charger AP page login

- Refer to 7.1 (Steps 1-6).
- Select 'Charger Setup'.

**Step 2: Selecting the charging modes**  
Select 'Switch Charging Modes'.

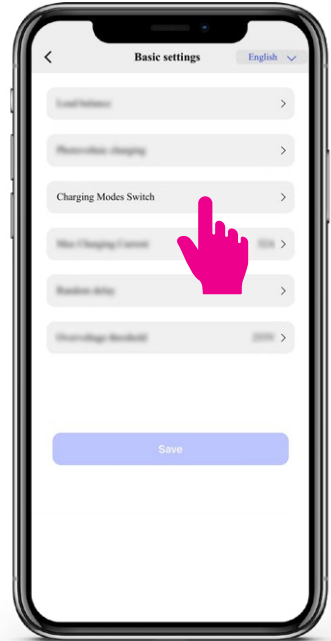

**Step 3: Plug & Play mode option**

This mode enables the user to charge the vehicle without any authorisation.

Charging starts as soon as the charger is plugged into the vehicle.

- Select 'Plug & Play' mode.
- Confirm.
- The charger will reboot after switching modes.

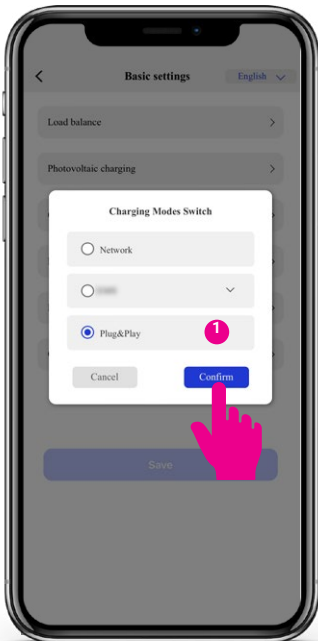

**Plug & Play mode should be used for RCD testing and should only be carried out by a qualified technician.**

#### Step 4: Test setup

- Connect the EVSE adapter to the charger.
- Connect the installation tester 3-pin plug into the EVSE adapter.
- An installation tester can be used to test the RCD of the charger by changing the load.
- Change the CP state of the EVSE adapter from 'A' to 'C' to start charging.
- Test the RCD is working with the installation tester by changing the load.

#### Step 5: EVSE adaptor setup

- The charger is off when CP state of the EVSE adaptor is in 'A' position.
- Change the CP state to 'C' to start charging.
- Change the CP state to 'A' to turn off charging.



After completing all the test steps (Steps 1-5), please change it to 'Network' mode.

# 8 Commissioning on Evcharge App

## a. Evcharge QR code commissioning

1. Select 'Charge point' on the bottom
2. Select 'Bind the charge point'
3. Select 'Scan the QR code'
4. Scan the EVcharge QR code from the side of the charger/ in the package.
5. Select 'Confirm'
6. Input the 4-digit pin found on the side of the charger/inside package.
7. Select 'Sign in'

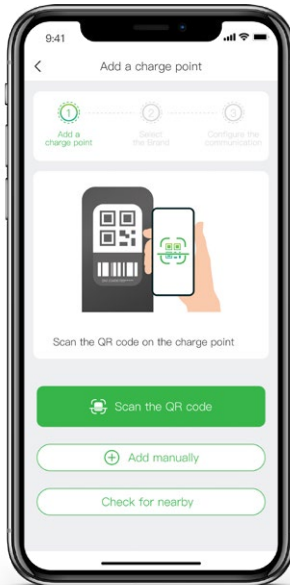
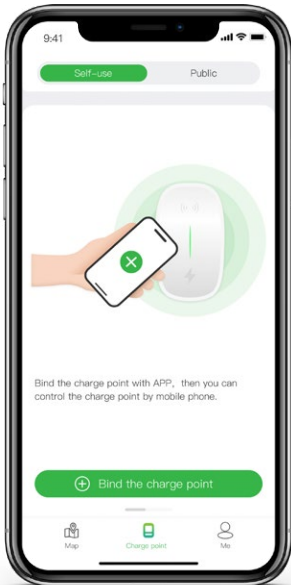

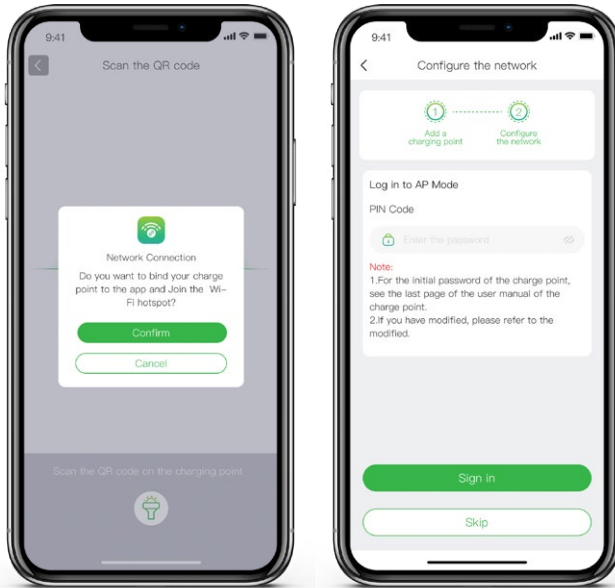

## **OR** b. Manual integration

1. Select 'Add manually'
2. Input the charger Serial Number on the app
3. Select the 'Cord' brand
4. Input the Charger Wi-Fi password found on the side of the charger/ package and connect to charger hotspot in the smartphone/laptop.
5. Go back to the Evcharge app > Input the 4-digit pin found on the side of the charger/inside package.
6. Select 'Sign in'

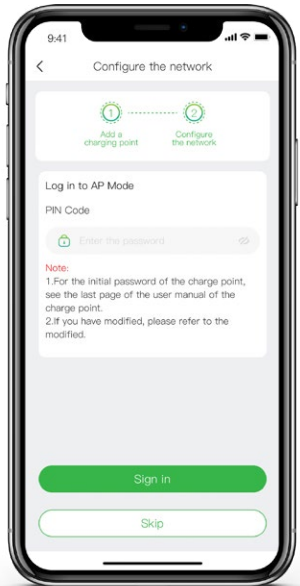
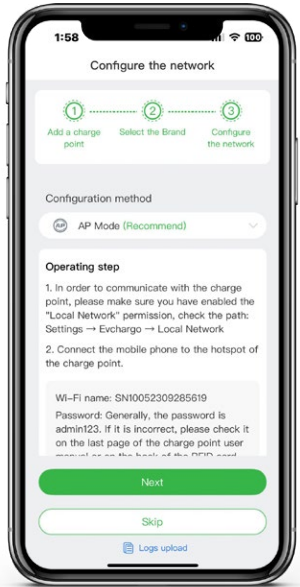
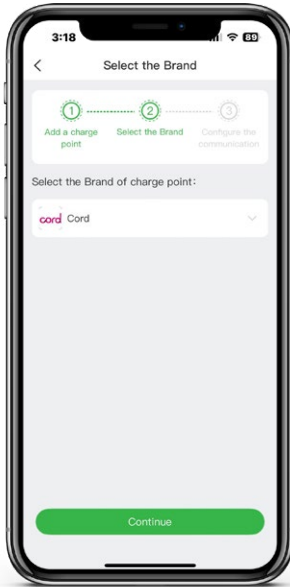
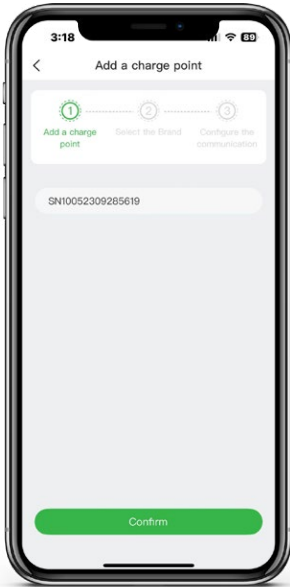

OR

### c. Check for nearby chargers

1. Select 'Check for nearby chargers'
2. Select the charger Wi-Fi Serial Number on the app
3. Select the 'Cord' brand
4. Select AP mode.
5. Select the charger Wi-Fi hotspot from the smartphone/laptop Wi-Fi hotspot list available. (e.g., SN10052....)
6. Input the Charger Wi-Fi password found on the side of the charger/ package and connect to charger hotspot in the smartphone/laptop.
7. Go back to the Evcharge app > Input the 4-digit pin found on the side of the charger/inside package.
8. Select 'Sign in'

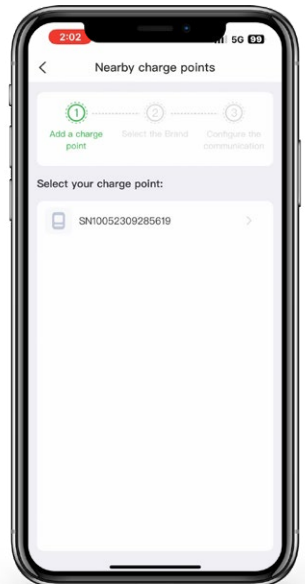
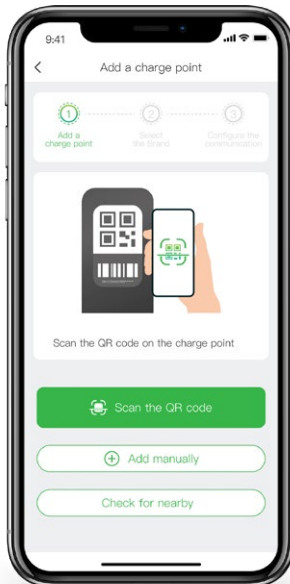
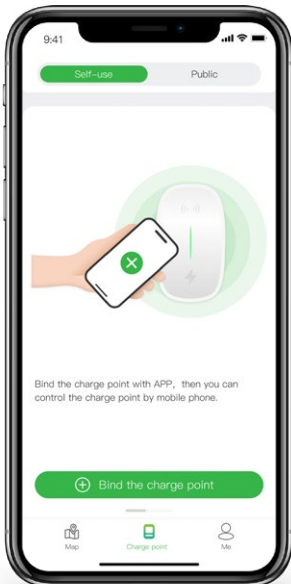

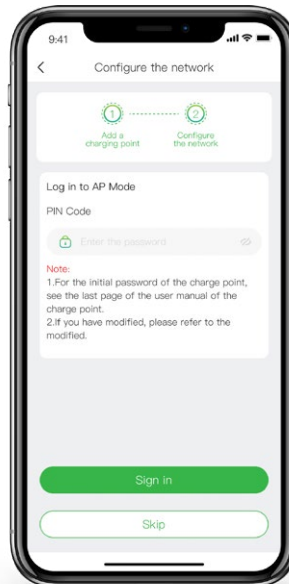
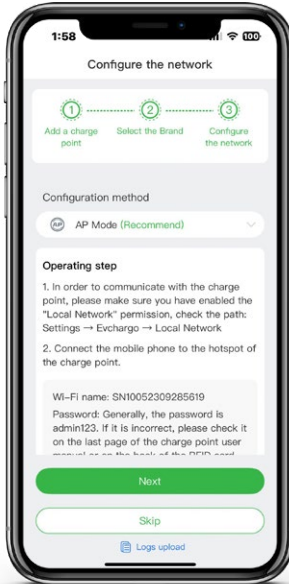
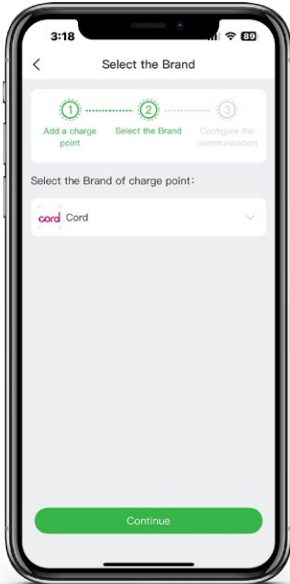

# 9 Network Settings

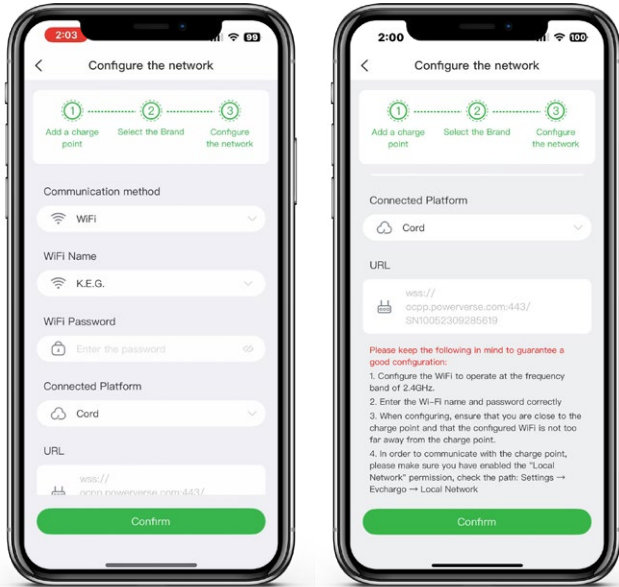

# 10 Load Balance

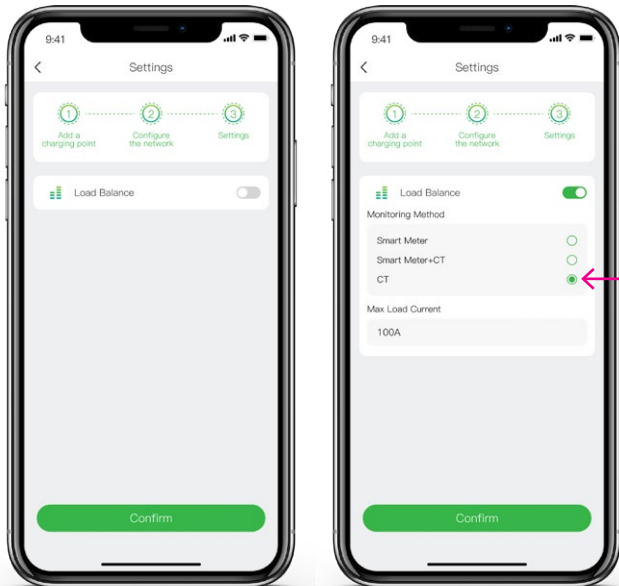

## 11 Final Step

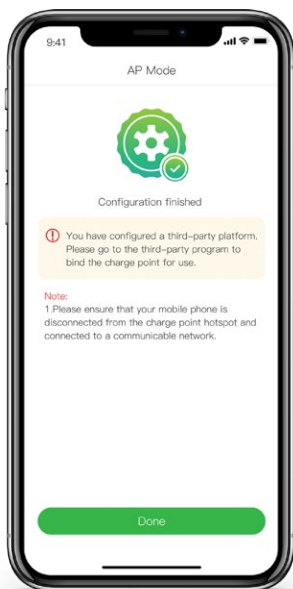

- The charger will reboot and save the settings after you select 'Done', completing the Evcharge commissioning.
- Download the Cord EV Charger app and follow the integration steps to start charging (Refer page 31).

# End User Guide



# 12 Cord EV Charging App User Guide

Follow the steps below to start using Cord EV app.

1. Download the Cord EV app from Google store/App store or by scanning the QR code below.
2. Scan the QR code below to refer the Cord EV user guide and complete the steps to integrate and start charging.



13

# Charging Operation LED Indication

## 13.1 Charging using app

Standby



Pulsing green,  
1s on, 3s off

Plug-in



Flashing green,  
200ms on, 1s off,  
3s off, 5 times, cycle

Charging



Flashing green,  
200ms on, 1s off,  
cycle

## 13.2 Charging using Plug & Play

Standby



Pulsing green,  
1s on, 3s off

Plug-in



Flashing green,  
200ms on, 1s off,  
3s off, 5 times, cycle

Charging



Flashing green,  
200ms on, 1s off,  
cycle

Fully Charged



Solid green light indicates the EV is fully charged.

Stop charging and unplug



Returns to standby mode after the charging has finished.

### 13.3 Charging using RFID card

Plug-in



Flashing green,  
200ms on, 1s off, 3s off,  
5 times, cycle.

Use RFID Card



Use the RFID card in the  
designated reading area.

A yellow indicator  
flashing, then turning  
green confirms the RFID  
card is successfully  
read and charging has  
started.

# UK EV Smart Charge Point Regulation

The UK government has introduced new rules and regulations around EV charging to ensure that consumers are protected and to tackle the rising electricity demand in the country.

The rules apply to the electric vehicle private charger which are sold for use in a domestic or workplace environment in Great Britain.

These measures were designed to help manage increasing electricity demand from the UK's transition to electric vehicles (EVs) and improve security protocols. The regulation details are as follows:

- Phase 1 of the UK government's Electric Vehicle (Smart Charge Points) Regulations 2021 came into force on 30 June 2022 and includes -
  - Randomised delay
  - Loss of communications network access
  - Default Charge settings
- On December 2022, Phase 2 of UK regulations came into effect now including built-in cyber security features -
  - Tamper boundary protection
  - Event logs for user privacy and data protection

## Phase 1

### 14.1 Randomised delay

- The regulations have made it mandatory to add the feature of 'Randomised delay' to protect the stability of the national electricity system from high volumes of chargers switching on or off at the exact same time.
- Under this regulation, the start or stop of a charger will be subjected to a random delay of up to 600 seconds. The user may experience that the charging session will not start at the exact scheduled time and should take this into account when checking the charging status.
- The user can override this delay in the app by selecting the "Switch to Charge now" right after the swipe to charge on each charging instances.

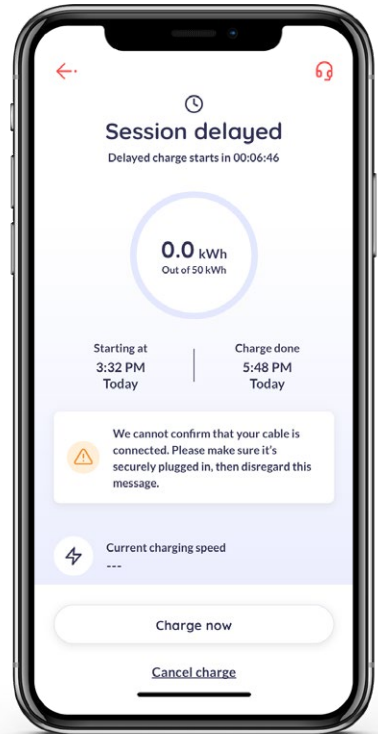

### 14.2 Loss of communications network access

- Under the UK regulations, the charger should be configured to charge the vehicle even if it loses connection to the communication network. In that situation, the charger is offline.
- To improve the experience for users, the charger should support local authorization of identifiers.
- The registered RFID cards can be used to charge the vehicle even if the charger is offline. (Refer 5.2.2)

### 14.3 Default charge schedule

- With the introduction of smart charge point regulations, the UK government imposed an off-peak charging feature to manage the electricity demand during peak hours.
- Off-peak charging only allows the user to charge the vehicle during off-peak hours. The chargers will not be able to operate from 8am to 11am and 4pm to 10pm which are considered as the peak hours during weekdays.
- There is no peak hour during weekends.

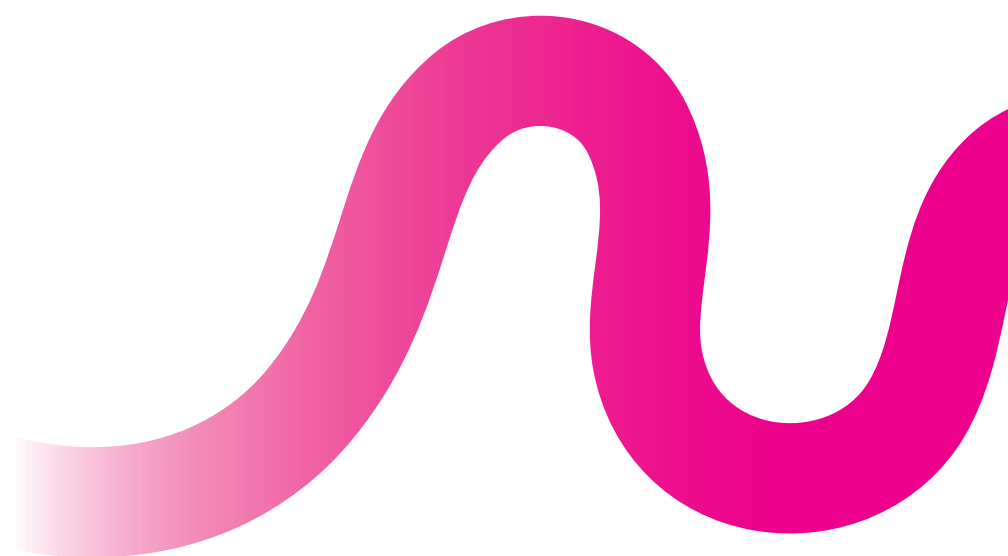

## Phase 2

### 14.4 Cyber security

On December 30th, 2022, Phase 2 of the UK Smart Charge Points Regulations—which includes several reinforced security measures to make owning and using an EV charger as secure as possible—went into effect .

The features that are important for the user to know are as follows:

- A “tamper-protection boundary” is included to secure the charger’s internal components. The charger will quickly log any unauthorised attempts to access it internally and notify the registered owner.
- The user’s personal information can be deleted from the Cord EV app by calling Cord EV customer support.
- The charger firmware updates will be provided for 3 years from the date of purchase.

The following measures are recommended for charger security:

- Remove the charger network pin sticker from the charger and keep it safe.
- The charger Access Point page is only open for 15 minutes, after which the page is inaccessible as a security precaution.
- Contact the Cord support immediately if the charger sends critical security event notification in the app.
- If the user receives notification from the app to upgrade, ensure upgrade is installed.
- The RFID cards should be kept secure.
- Ensure the Cord EV account has a strong password.

# 15 Troubleshooting

## 15.1 Indicator status

State	Description	Led Status
In standby	Normal	Pulsing green, 1s on, 3s off
Charging status	Normal	Flashing green, 200ms on, 1s off, cycle
Plugged gun state	Normal	Flashing green, 200ms on, 1s off, 5 times, 3s off, cycle
Software upgrade	Normal	Flashing white, 200ms on, 1s off, 5 times, 5s off, cycle
Relay fault	Fault	Red light normally on
Leakage current	Fault	Flashing red, 500ms, 500ms off, 3s off, 1 time, cycle
CP fault	Fault	Flashing red, 500ms on, 500ms off, 3s off, 2 times, cycle
Overload fault	Fault	Flashing red, 500ms on, 500ms off, 3s off, 3 times, cycle
Input polarity reverse	Fault	Flashing red, 500ms on, 500ms off, 3s off, 4 times, cycle
Leakage current loop abnormal	Fault	Flashing red, 500ms on, 500ms off, 3s off, 5 times, cycle
Input terminal overtemperature	Fault	Flashing red, 500ms on, 500ms off, 3s off, 6 times, cycle
Relay overtemperature	Fault	Flashing red, 500ms on, 500ms off, 3s off, 7 times, cycle
Under voltage fault	Fault	Yellow light, 2s on, flashing red light, 500ms on, 500ms off, flashes 1 time, 3s off, cycle
Over voltage fault	Fault	Yellow light, 2s on, flashing red light, 500ms on, 500ms off, flashes 1 time, 3s off, cycle
Over frequency fault	Fault	Yellow light, 2s on, flashing red light, 500ms on, 500ms off, flashes 2 times, 3s off, cycle
Under frequency fault	Fault	Yellow light, 2s on, flashing red light, 500ms on, 500ms off, flashes 2 times, 3s off, cycle
Incorrect load balance activation/connection	Fault	Yellow light, 2s on, flashing red light, 500ms on, 500ms off, flashes 5 times, 3s off, cycle
Ground warning	Normal	Yellow light, 2s on, flashing red light, 500ms on, 500ms off, flashes 8 times, 3s off, cycle

## 15.2 Fault code and resolution

Problems	Possible Causes	Solutions	Automated Recovery
<b>Overvoltage</b>	AC input voltage is too high	<ol style="list-style-type: none"> <li>1. Check the charger input voltage.</li> <li>2. If the voltage is over 253Vac for a short time, please wait until the power grid recovers to the normal voltage range.</li> </ol>	The charger immediately recovers once the input voltage is within range.
<b>Undervoltage</b>	AC input voltage is too low	<ol style="list-style-type: none"> <li>1. Check the charger input voltage.</li> <li>2. If the voltage is under 207Vac for a short time, please wait until the power grid recovers to the normal voltage range.</li> </ol>	The charger immediately recovers once the input voltage is within range.
<b>Overload/ Over-current</b>	AC output current is too high	<ol style="list-style-type: none"> <li>1. Shut off the breaker switch in the distribution/consumer unit immediately if it hasn't already.</li> <li>2. Check whether there is low resistance path on the output cable and charging gun.</li> </ol>	The charger recovers to normal state once the charging gun is plugged out from the vehicle.
<b>Overfrequency</b>	AC input frequency is too high	<ol style="list-style-type: none"> <li>1. Check the input voltage frequency from the backend.</li> <li>2. If the frequency exceeds 63Hz for a short time, wait till power grid recover to normal voltage range.</li> </ol>	The charger immediately recovers once the electrical frequency is within range.
<b>Underfrequency</b>	AC input frequency is too low	<ol style="list-style-type: none"> <li>1. Check the input voltage frequency from the backend.</li> <li>2. If the frequency is lower than 47Hz for short time, wait till power grid recover to normal voltage range.</li> </ol>	The charger immediately recovers once the electrical frequency is within range.
<b>Input terminal over-temperature</b>	Temperature inside the charger is too high	<ol style="list-style-type: none"> <li>1. Check the surrounding conditions of chargers installed whether there is heat source nearby. Make sure surrounding temperature is under 60°C.</li> <li>2. Please ensure the electrical cable and terminal integrity before powering the charger.</li> </ol>	The charger recovers when the temperature is back to normal.
<b>Leakage current</b>	Leakage current to earth is too high	<ol style="list-style-type: none"> <li>1. Shut off the breaker switch in the distribution/consumer unit immediately.</li> <li>2. Shut off the breaker switch in the distribution/consumer unit immediately.</li> </ol>	The charger recovers to normal state once the charging gun is plugged out from the vehicle.
<b>Reversed input polarity</b>	Reversed connection of L/N input cable	<ol style="list-style-type: none"> <li>1. Shut off the breaker switch in the distribution/consumer unit immediately.</li> <li>2. Check if AC input/output cables are connected in the correct polarity and rectify accordingly.</li> </ol>	The charger immediately recovers once the input terminal is connected in the correct polarity.
<b>Faulty Leakage Current Monitoring System</b>	Connection issue on the leakage detection current transformer	<ol style="list-style-type: none"> <li>3. Please check the port connection of the current transformer clamped to the outgoing line and neutral cable.</li> </ol>	The charger recovers when the connection of leakage detection current transformer is resolved.
<b>Ground Warning</b>	Loose connection on incoming CPC cable or unstable incoming voltage	<ol style="list-style-type: none"> <li>1. Please tighten the incoming CPC/ grounding cable inside the charger.</li> <li>2. If tightening does not resolve the issue, please wait until the incoming voltage stabilize.</li> </ol>	The charger immediately recovers once grounding cable is tightened and the voltage is stable.

Note: If the problem occurs, please visit: [www.cord-ev.com](http://www.cord-ev.com)

### 15.3 Forgot the Access Point password?

Reset the password by following the steps below:

1. Power reboot the charger
2. Press and hold the reset button for 10s.  
This will revert to the default PIN code.
3. Access the AP page (Refer to 7.1, steps 1-7).  
Input the default 4-digit PIN code in the charger sticker.
4. Input the new 8-digit password.

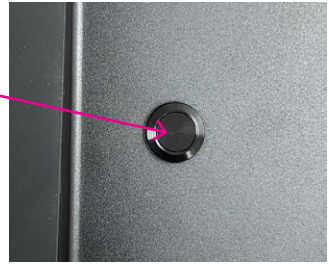

## 16 Maintenance

No.	Item	Operating Process
1	Charger components	Use a dry non-static cloth to clean the charger surface. If there is any damage on the vehicle connector, charging cable, or vehicle connector holder, please contact customer service immediately.
2	Charger casing	Do not hit or press hard on the case. If the case is damaged, please contact customer service.
3	Moisture and water notice	If you notice any water or moisture inside the charger, it is important to immediately turn off the electricity supply to prevent any potential danger. Before using the station again, contact a qualified electrician.
4	Flammable substance	It is important to ensure that the charger is kept away from hazardous materials, such as flammable gases and corrosive substances.

# 17 Security Events and Customer Support

## 17.1 Security events

Notification	Function
Firmware updated	The Charger firmware is updated
Startup of the device	The Charger has booted
Reset or reboot	The Charger was rebooted or reset
Security log was cleared	The security log was cleared
Memory exhaustion	The Flash or RAM memory of the Charger is getting full
Tamper detection activated	The physical tamper detection sensor was triggered



## 17.2 Cord customer support

Need some assistance?  
For additional support, contact our customer service team.

**Telephone:** +44 (0) 330 102 5656

**Email:** [hello@cord-ev.com](mailto:hello@cord-ev.com)

**Visit:** [www.cord-ev.com](http://www.cord-ev.com)



[www.cord-ev.com/knowledgebase](http://www.cord-ev.com/knowledgebase)

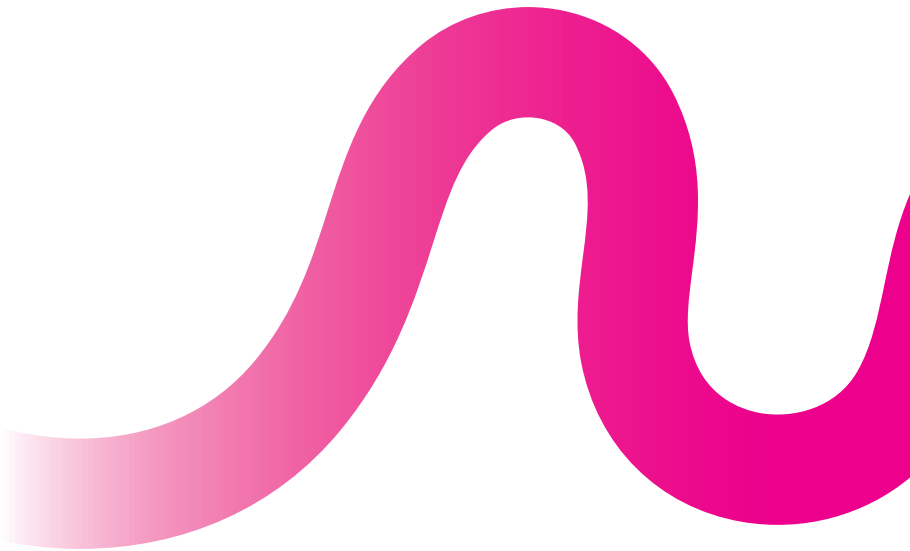

# cord

## Get in touch

[www.cord-ev.com](http://www.cord-ev.com)

[hello@cord-ev.com](mailto:hello@cord-ev.com)

+44 (0) 330 102 5656

June 2025, SKU: P350690007-00 (A01)

Smart  
Charge Points  
Regulations  
**COMPLIANT**

